

# Installation Instructions

**S3-0,9-160-17-40 100Hz**

-

Model: 10003668 10004

---

GfA ELEKTROMATEN GmbH & Co. KG  
Wiesenstraße 81  
D-40549 Düsseldorf  
🌐 [www.gfa-elektromaten.de](http://www.gfa-elektromaten.de)  
✉ [info@gfa-elektromaten.de](mailto:info@gfa-elektromaten.de)

---

Table of contents

1	General safety information .....	4
2	Technical Data .....	5
3	Mechanical installation .....	6
4	Electrical installation .....	10
5	Limit switch adjustment .....	11
6	Motor connection .....	12
7	Limit switch connection .....	12
1	Emergency manual operation NHKK (emergency hand crank with joint) .....	13
2	Completing commissioning / inspection.....	14

**Symbols**



**Warning** - Potential injury or danger to life!



**Warning** - Danger to life from electric current!



**Note** - Important information!



**Requirement** - Required action!

Schematic representations are based on product examples. Deviations from delivered products are possible.

---

## 1 General safety information

### Specified normal use

The drive unit is intended for doors, which have to be secured against falling down; a safety brake is included in the gearbox. The drive unit is directly mounted on the door shaft.

The safe operation is only guaranteed with normal specified use. The drive unit is to be protected from rain, moisture and aggressive ambient conditions. No liability for damage caused by other applications or non-observance of the information in the manual.

Modifications are only permitted with the agreement of the manufacturer. Otherwise the Manufacturer's Declaration shall be rendered null and void.

### Safety information

Installation and initial operation tasks are to be performed by trained, skilled fitters only.

Only trained electrical craftsmen are permitted to work on electrical equipment. They must assess the tasks assigned to them, recognise potential danger zones and be able to take appropriate safety measures.

The installation is only to be carried out with the supply off.

Observe the applicable regulations and standards.

### Coverings and safety devices

Do not operate unless corresponding coverings and safety devices are fitted/installed.

Ensure that gaskets are correctly positioned and cable glands are correctly tightened.

### Spare parts

Use only original spare parts.

## 2 Technical Data

Type	SG 85F	
Output torque	150	Nm
Output speed	160	rpm
Output shaft / hollow shaft	40,00	mm
Locking torque moment	480	Nm
Safety brake (testhouse/approval number)	14-003612-PR03	
Maximum output speed open / close for frequency inverter operation	200 / 90	rpm
Supply voltage	3~ 380	V
Operating current	5,20	A
Operating frequency	100	Hz
Power factor $\cos \varphi$	0,43	
Maximum movement per hour	30	$h^{-1}$
Hand forces	184	N
Class of protection	IP 54	
Limit switch range (maximum revolutions of output shaft / hollow shaft)	20	
Braking torque	11	Nm
Braking voltage	24	V DC
Rectifier type	-	
Temperature range	-10 / +50 (+60)	$^{\circ}\text{C}$

1) When using a temperature range of +50°...+60°C use half of maximum movements per hour.

### 3 Mechanical installation

#### Prerequisites

The permissible loads on walls, fastenings, mountings and transmission elements must not be exceeded, even for maximum holding torques or locking torques (► refer to technical data).

#### Connection elements

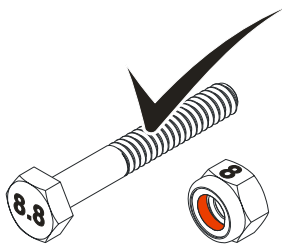
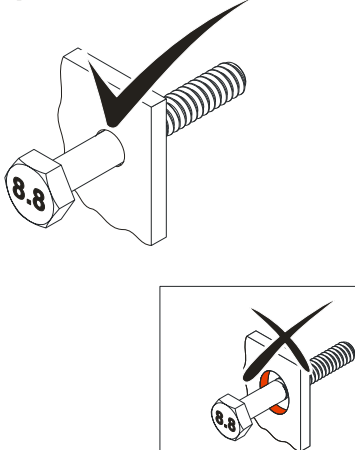
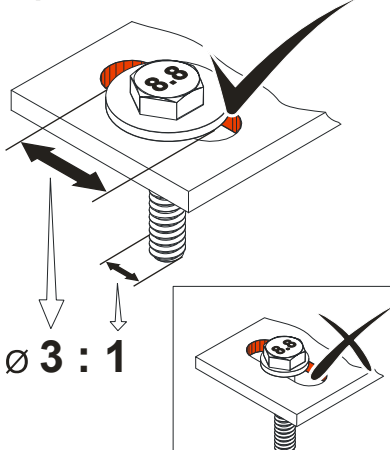
<ul style="list-style-type: none"><li>► Self-locking connection elements with a minimum strength of 800 N/mm<sup>2</sup> (8.8) must be used.</li></ul>	<ul style="list-style-type: none"><li>► Utilize the hole diameter to the full.</li></ul>	<ul style="list-style-type: none"><li>► Use adequately dimensioned washers for elongated holes.</li></ul>
<p><small>BAGAB00001_2002</small></p>  <p><b>≥ 800 N/mm<sup>2</sup></b></p>	<p><small>BAGAB00002_2002</small></p> 	<p><small>BAGAB00003_2002</small></p>  <p><b>Ø 3 : 1</b></p>

#### Permissible mounting positions

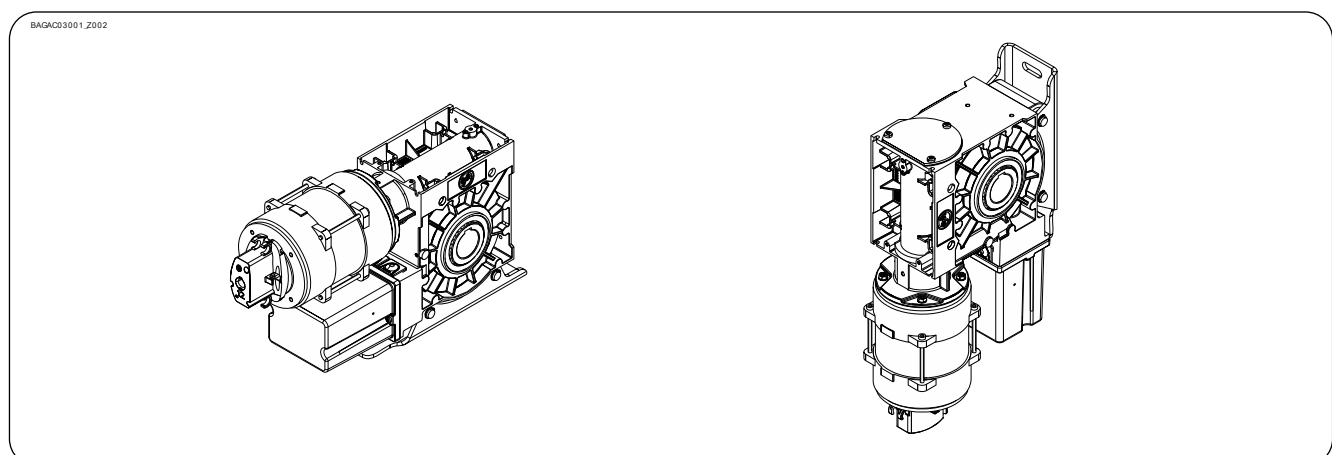

## Mounting

Two elongated holes are provided for mounting.

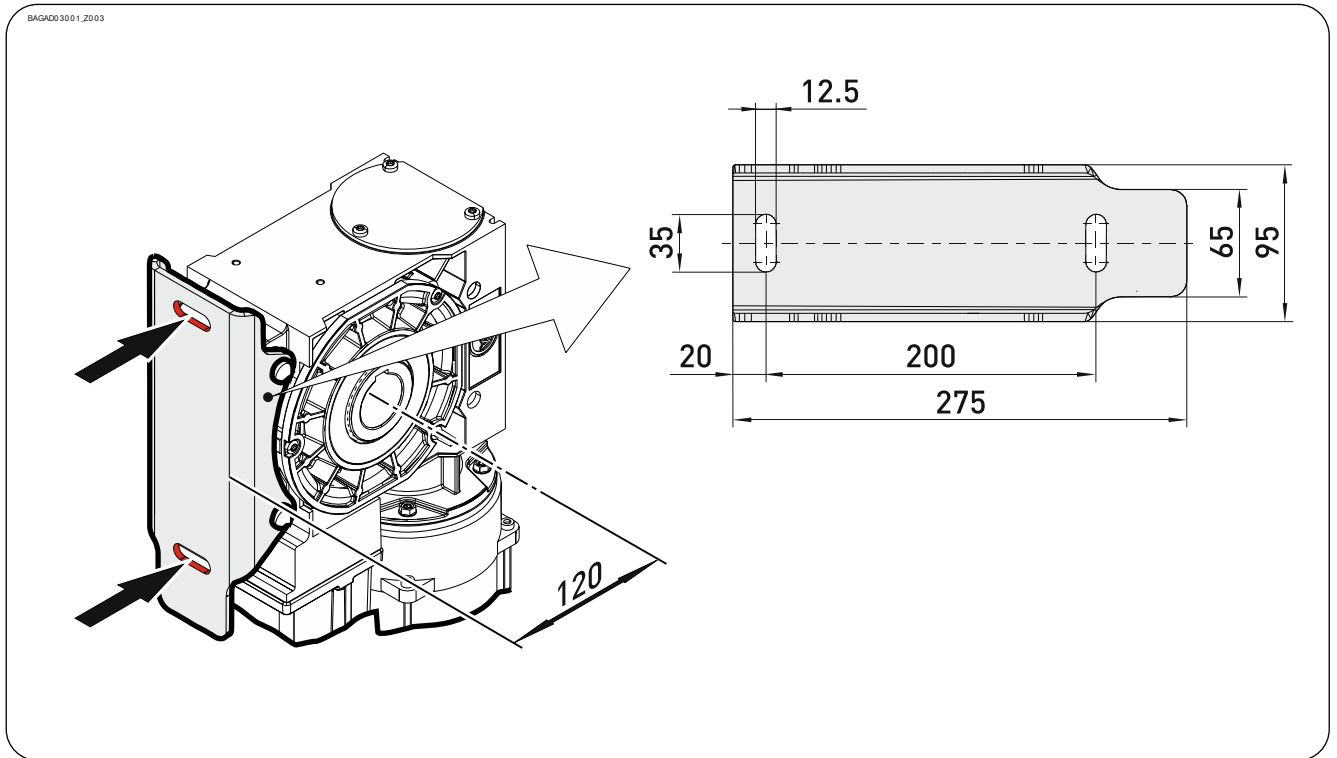

## Installation

The descriptions below apply to general door specifications. The specifications of the door manufacturer must also be observed during installation.



Warning - Potential injury or danger to life!

- During installation, be sure to use a lifting device that has a sufficient load-carrying capacity.

- ▶ Thoroughly grease the door shaft.

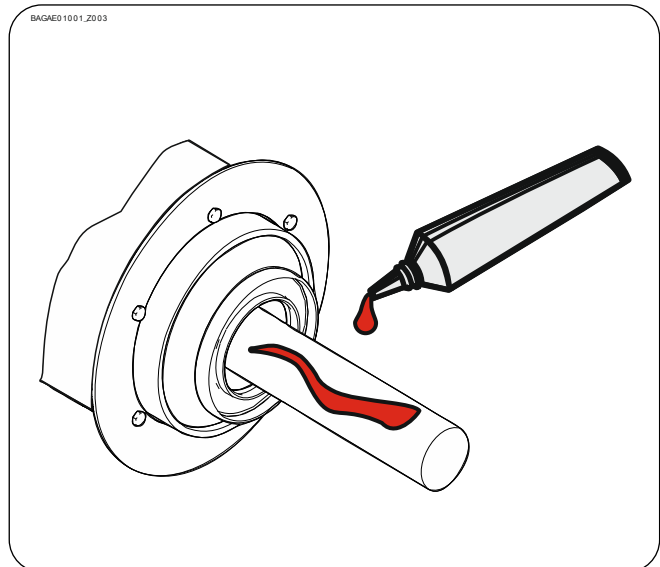

- ▶ Mount the keys.

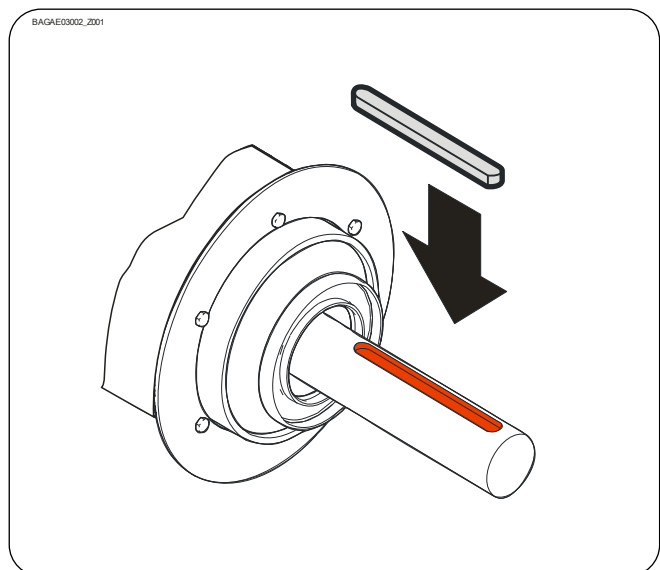



- ▶ Attach the drive unit.

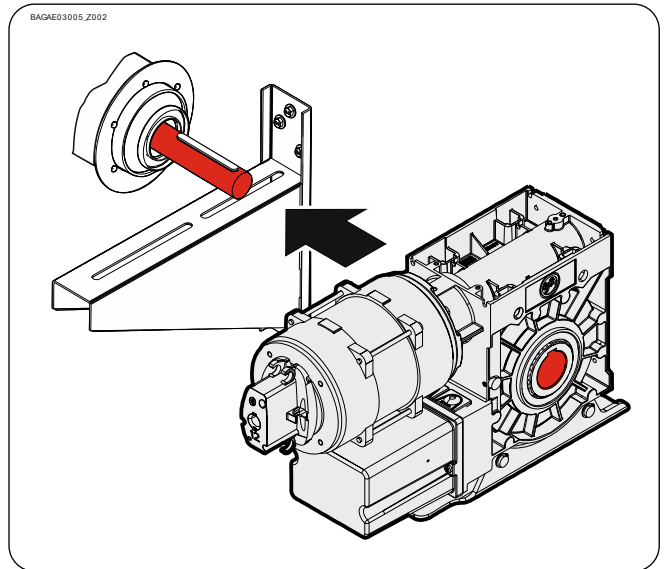

- ▶ Tighten all connection elements (M12) to 75 Nm. Install all other connection elements according to the specifications of the door manufacturer.

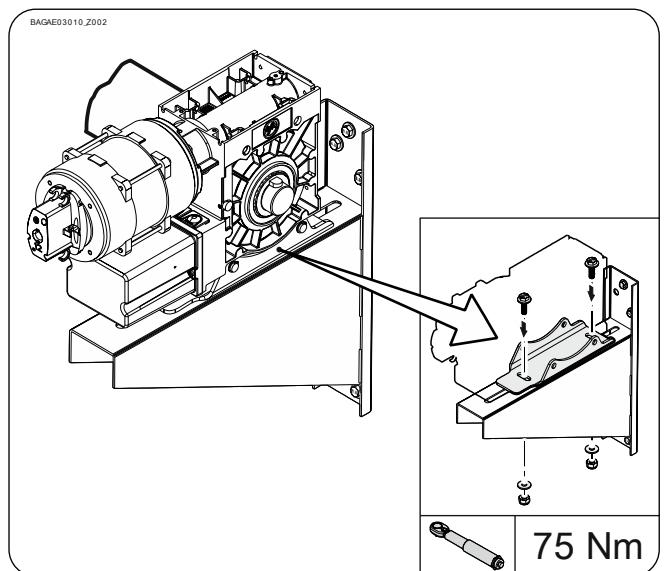

## 4 Electrical installation



**Warning - Danger to life from electric current!**

- Switch the mains OFF and check that the cables are de-energised
- Observe the applicable regulations and standards
- Make a proper electrical connection
- Use suitable tools

### Performing electrical installation

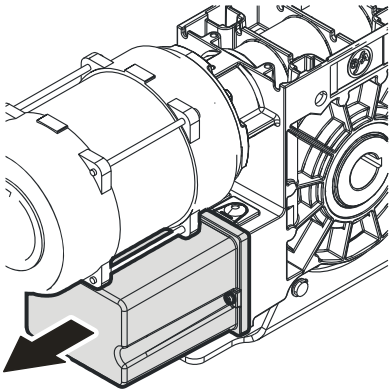
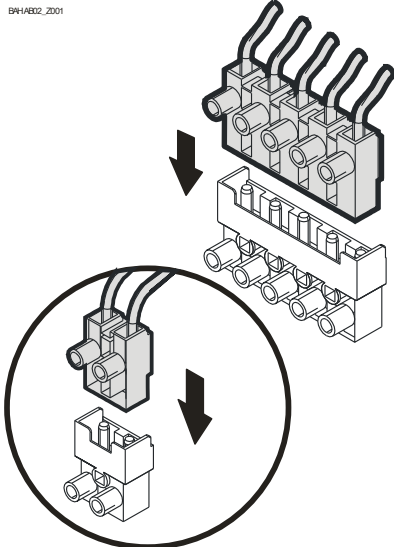
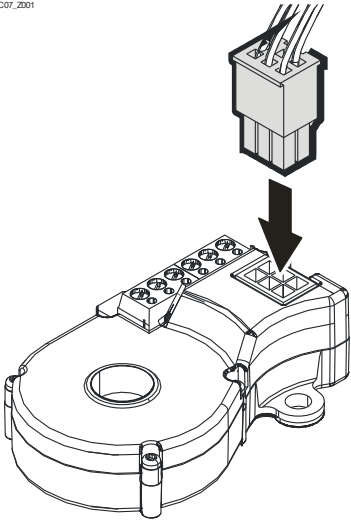
Remove the cover.	Insert the motor plug and brake plug.	Insert the limit switch plug.
<small>BH4A03_2001</small> 	<small>BH4A02_2001</small> 	<small>BH4A07_2001</small> 

### Completing the electrical installation

Mount the cable entries and/or cable glands.

---

## 5 Limit switch adjustment

The adjustment of the final limit positions OPEN and CLOSE is described in the instructions for the door control panel.

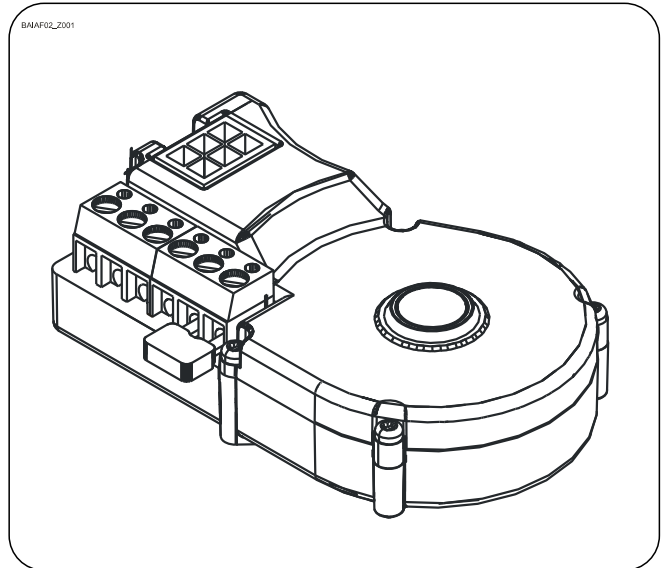

## 6 Motor connection

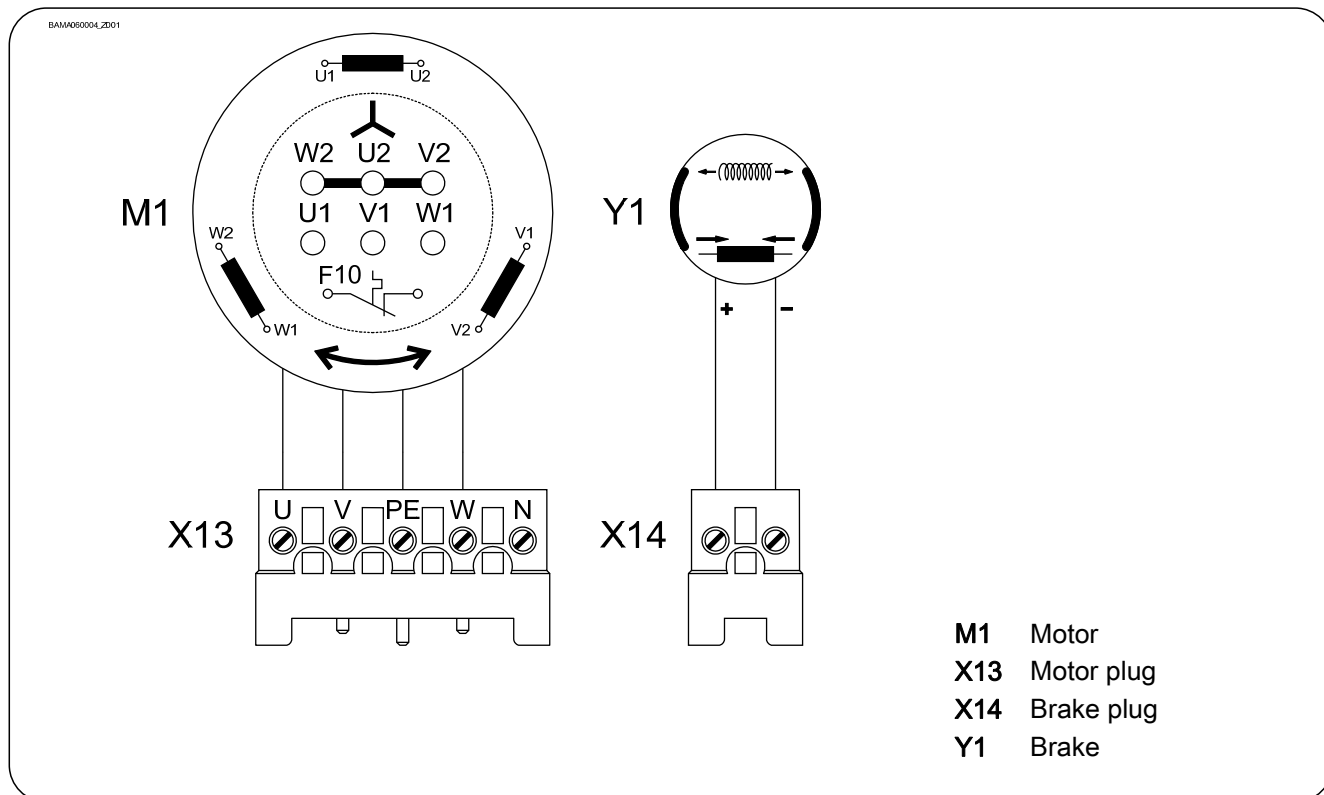

## 7 Limit switch connection

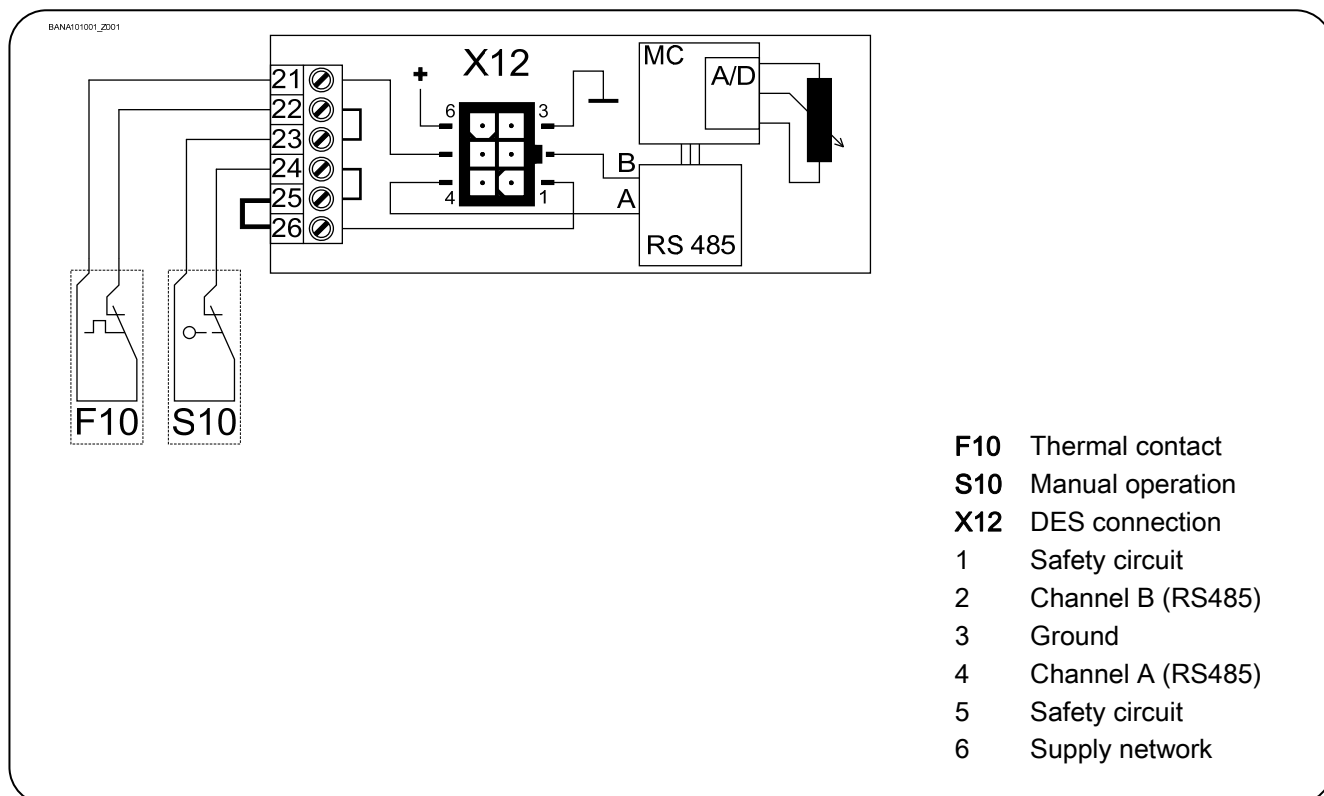

## 1 Emergency manual operation NHKK (emergency hand crank with joint)

The emergency manual operation is provided as a means of opening or closing doors that do not have electric power supply. Operation interrupts the control voltage. Electrical operation is no longer possible.



**Warning - Injury through improper operation or falling objects!**

- Disconnect the voltage
- Adopt a secure position
- For drives that have a brake, emergency manual operation should be carried out with the brakes on



**Caution - Component damage can result!**

- Do not move the door beyond the final limit positions.

Insert the crank and turn it until it latches (①).

Turn the crank to open or close (②).

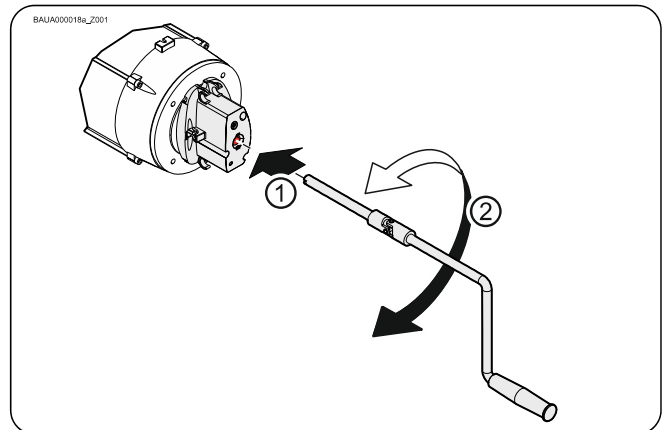

The crank can be mounted to the drive unit after usage.

- ▶ Mounting only as displayed.

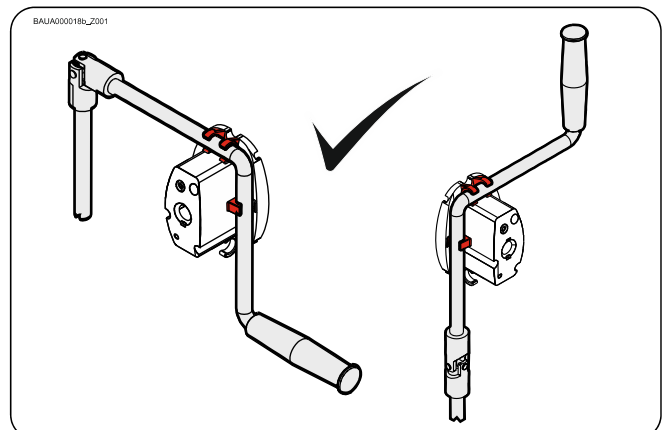

---

## 2 Completing commissioning / inspection

Check the following components and then install all covers.

### **Gearbox**

Check the drive unit for loss of oil (a few drops can be neglected). Protect the output-shaft permanently against corrosion.

### **Safety brake in the gearbox**

The safety brake is maintenance-free and requires no checking.

### **Mounting**

Check that all connection elements (consoles, torque mounts, screws, locking rings, etc.) are secure and in proper condition.

### **Electrical wiring**

Check the connection cables and cabling for damage or crushing. Check that the screw connections and plug connections are fitted properly with a good electric contact.

### **Emergency manual operation**

Check the function with the power disconnected. Perform the check only between the final limit positions.

### **Limit switch**

Check the final limit positions by opening and closing fully. The safety area must not be approached.

---

## Brake



### Warning - Potential injury or danger to life!

- Carry out a brake test. Overrun depends on the door and its equipment. The specifications of the door manufacturer must be observed.
- Brake lift may only be used in the final limit position CLOSE for doors that have no counter-balancing.



### Warning - Potential injury or danger to life!

Lifecycle brake - change complete brake unit at:

- Operation with mains supply after 250.000 cycles
- Operation with Inverter after 1.000.000 cycles

In an environment that can affect the coefficient of friction of the brake pad (atmosphere with oil, solvents, detergents, etc.), class of protection IP65i must be adopted.

## Drive unit



### Note!

- Engage a qualified engineer to check the drive unit annually
- Apply shorter inspection intervals for doors that are operated frequently
- Observe the applicable regulations and standards

# Declaration of Incorporation

in the terms of Machinery Directive 2006/42/EC  
for partly completed machinery, Appendix II Part B



# Declaration of conformity

in terms of EMC Directive 2014/30/EU

GfA ELEKTROMATEN GmbH & Co. KG  
Wiesenstraße 81 · 40549 Düsseldorf  
Germany

We, the  
**GfA ELEKTROMATEN GmbH & Co. KG**  
hereby declare that the following products are conform with the above  
EC Guideline and are only intended for installation in door equipment.

## SI 15.160-40,00

### Standards applied

<b>DIN EN 12453:2001-02</b>	Industrial, commercial and garage doors and gates - Safety in use of power operated doors - Requirements
<b>DIN EN 12604:2000-08</b>	Industrial, commercial and garage doors and gates - Mechanical aspects - Requirements
<b>DIN EN 60335-1:2012-10</b>	Household and similar electrical appliances - Safety - Part 1: General requirements
<b>DIN EN 61000-6-2:2006-03</b>	Electromagnetic compatibility (EMC) Part 6-2 Generic standards – Immunity standard for industrial environments
<b>DIN EN 61000-6-3:2011-09</b>	Electromagnetic compatibility (EMC) Part 6-3 Generic standards – Emission standard for residential, commercial and light-industrial environments

We undertake to transmit in response to a reasoned request by the appropriate regulatory authorities the special documents on the partly completed machinery.

### Authorised representative for the compilation of the relevant technical documents

(internal EU address)  
Dipl.-Ing. Bernd Synowsky  
Documentation representative

Incomplete machines within the meaning of the EC Directive 2006/42/EC shall only be intended to be integrated into other machines (or into other incomplete machines/systems) or to be assembled with them to form a complete machine within the sense of the Directive. Therefore, this product cannot be commissioned before it is determined that the entire machine/system to which it was integrated shall comply with the provisions of the Machinery Directive indicated above.

Düsseldorf, 10.07.2017

**Stephan Kleine**  
CEO

  
Signature